



SEPOR PILOT PLANTS

Sepor has years of experience fabricating, installing, and commissioning pilot plants from a few kg per hour up to a few tonnes per hour in capacity. Sepor can provide the crushing, milling, classification and leaching or gravity/flotation concentration circuits based on your needs. We offer thickeners and filters as well for handling concentrates and tailings. If required, Sepor Services LLC can assist with the NI43-101 level design and evaluation of your project as well.

Sepor is a One Stop Shop for your Pilot Plant requirements. Please complete the attached questionnaire with as much detail as possible and we will respond within a short time.

Below you can see some examples of our products.



**Testing & developing
various mineral
processing
technology**

**Offers a wide range of
equipment and
machinery for
conducting small-
scale experiments**

**Ensures Accurate and
reliable results
through its dedication
to quality control and
adherence to industry
standards**

SEPOR.COM

West Coast: 718 N. Fries
Avenue Wilmington, CA
90744

East Coast: 3740 NW 124th
Ave, Coral Springs, FL 33065

Telephone
(310)830-6601



COMMINUTION

1.5 CUBIC METER LEACH TANKS IN SERIES CAN BE CONVERTED TO CIL WITH CARBON SCREEN ADDITION

COMMINUTION FLOWSHEET

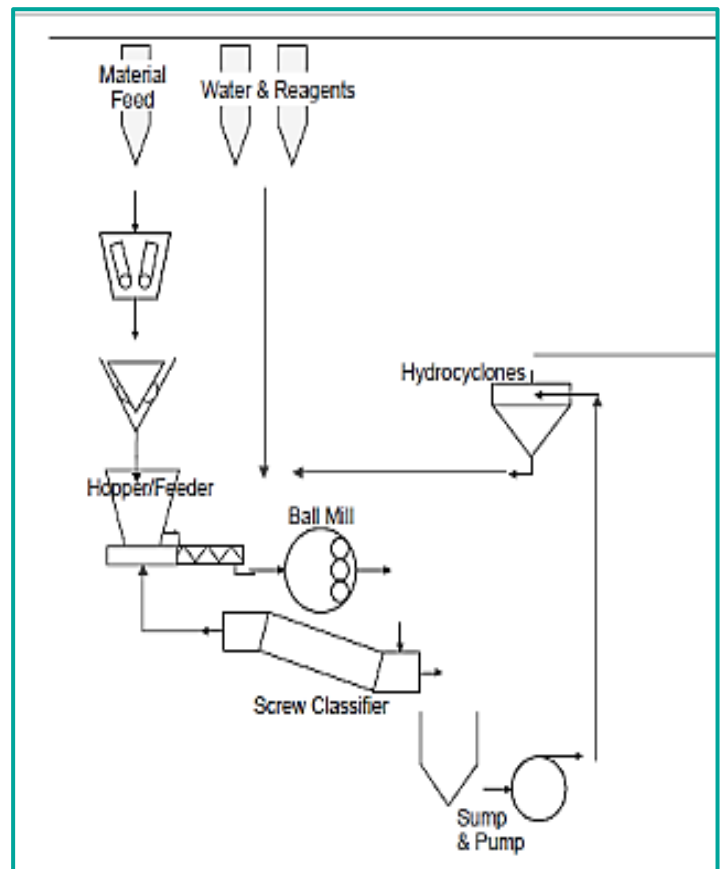

**50 KG/HR WITH SCREW
CLASSIFIER AND
CYCLONE RECYCLE**



**100 KG/HR MILL W/SUMPS
1 SUMP FOR TROMMEL USIZE
2SUMP FOR TROMMEL OSIZE
(TROMMEL NOT SHOWN)**



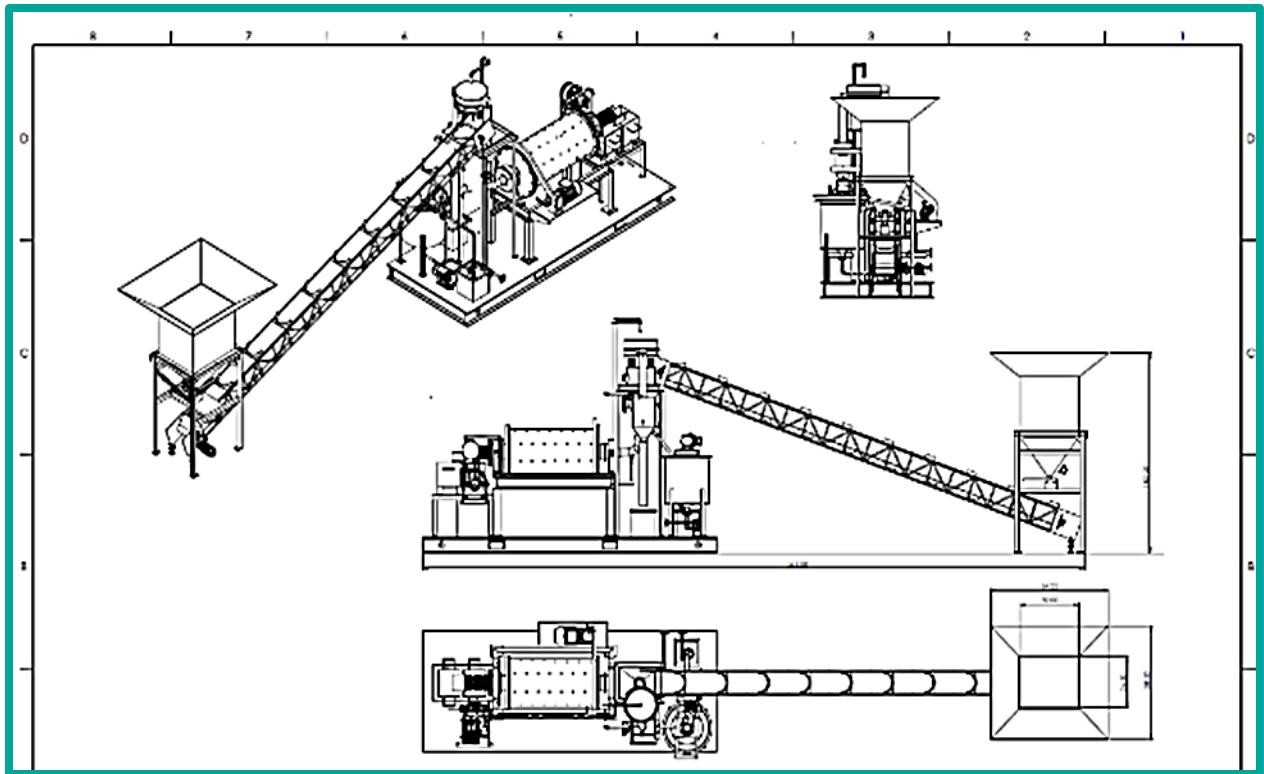

BELT CONVEYOR FEED

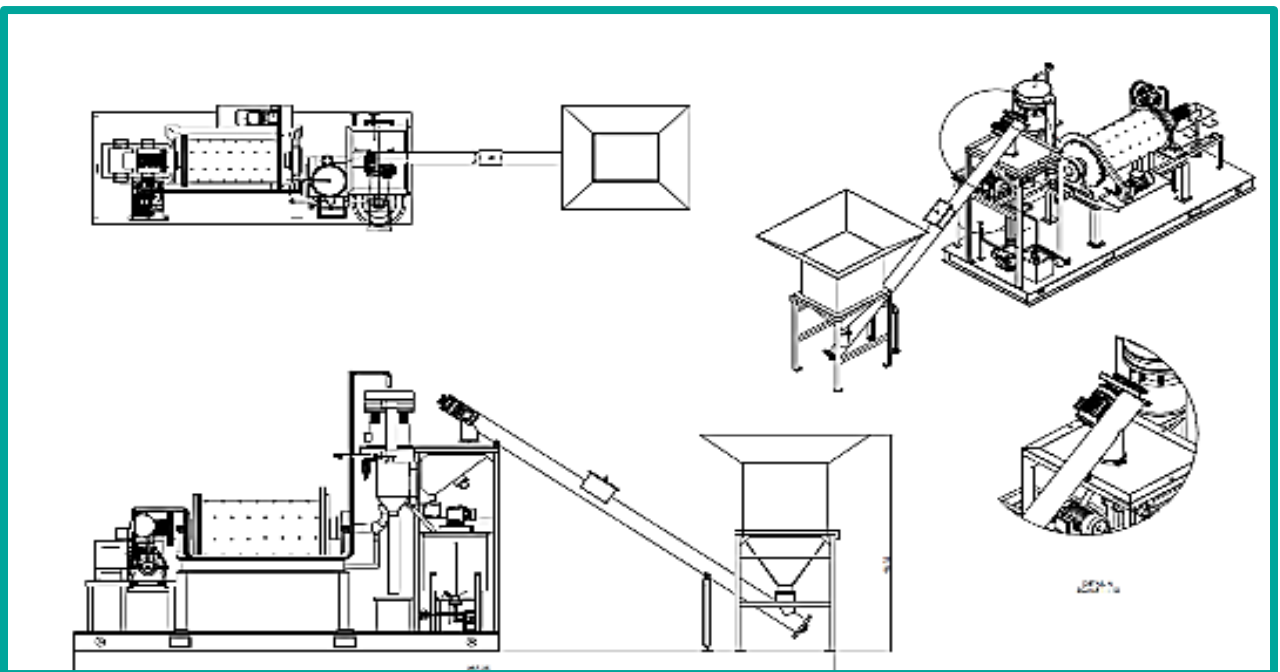

SCREW CONVEYOR FEED

SS DRUMS AS CIL TANKS



LEACH TANKS

1.5 CUBIC METER LEACH TANKS IN SERIES CAN BE CONVERTED TO CIL WITH CARBON SCREEN ADDITION

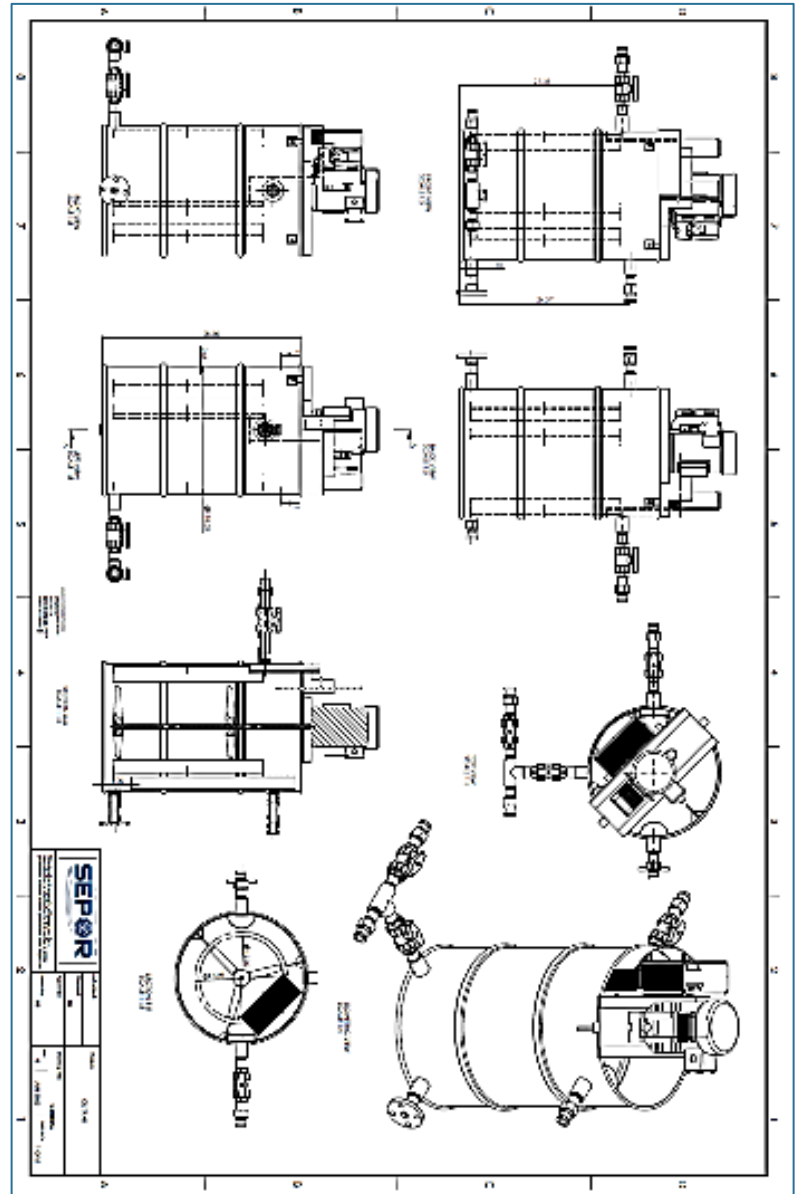

HYDROCYCLONES



SCREW CLASSIFIER

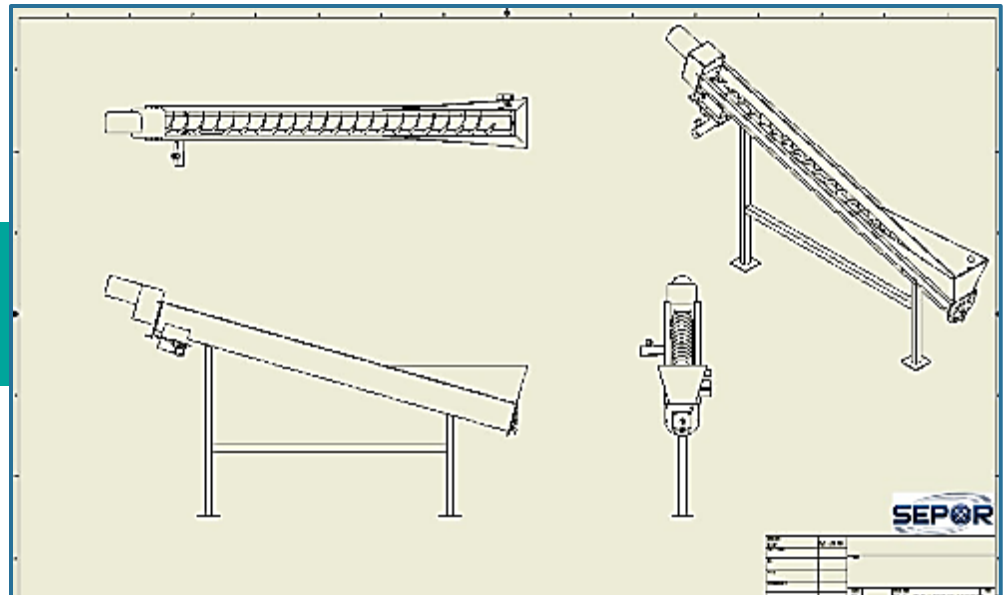



**18" Dia., 2 Deck
Vibro Energy Screen**

SCREEN DECKS



THICKENERS

FROM 2' TO 12'
DIAMETER
AVAILABLE

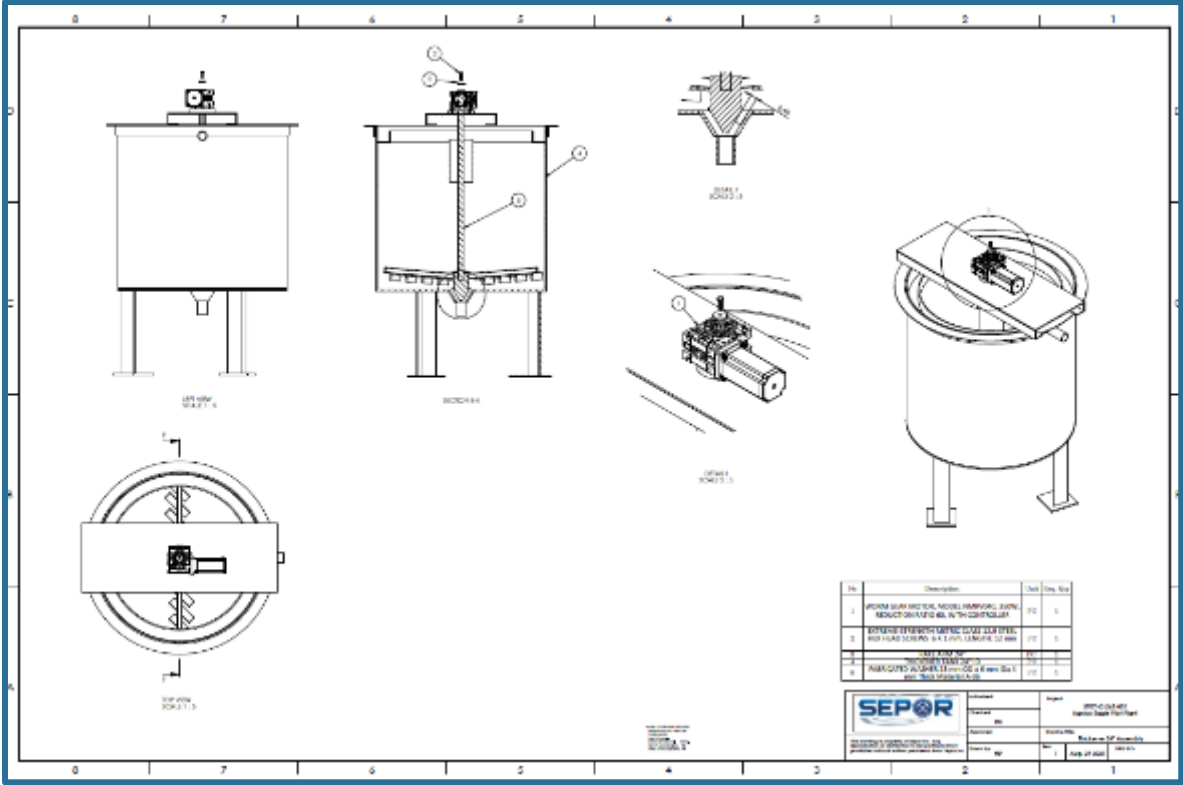

6' THICKENER WITH
CORROSION RESISTANT
COATING

CONCENTRATION



**MERRILL
CROWE
CIRCUIT 100
GPM**

**CENTRIFUGAL
CONCENTRATORS**



FLOTATION CELLS

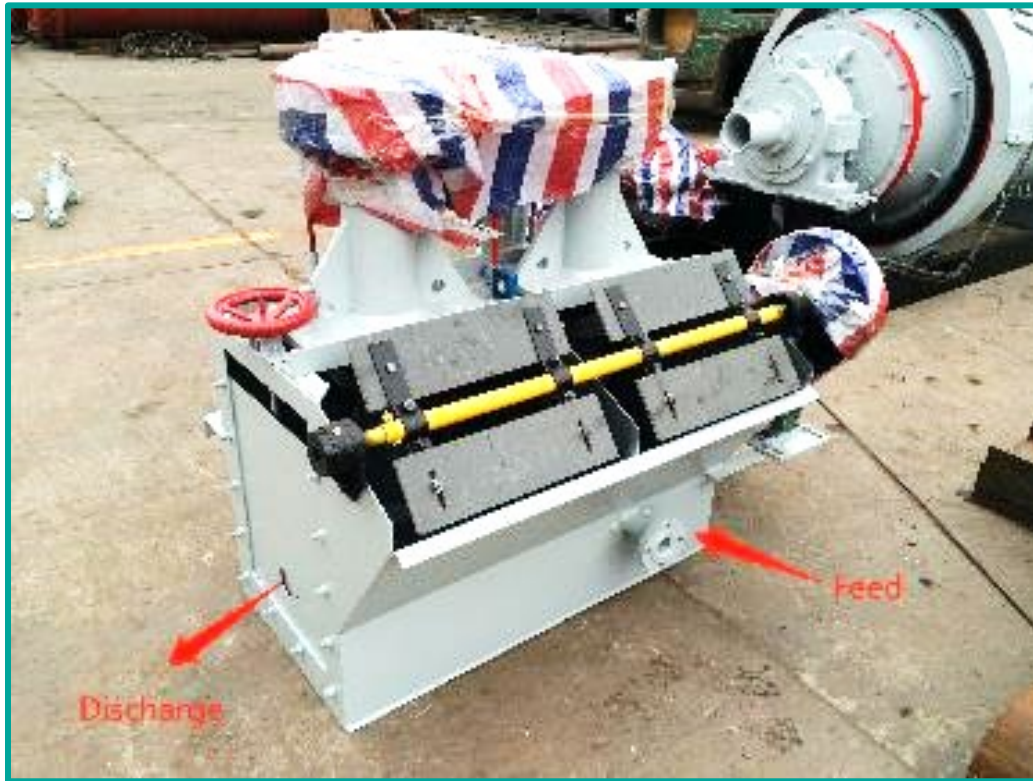



PILOT PLANT - MODULAR SKID QUESTIONNAIRE

CUSTOMER NAME: _____

CONTACT INFORMATION:

ADDRESS: _____

EMAIL: _____

PHONE: _____

FAX: _____

WEBSITE: _____

POSITION: _____

CONTACT NAME: _____

PREFERRED METHOD OF CONTACT: PHONE _____ EMAIL _____

HAVE YOU PURCHASED FROM SEPOR BEFORE? _____ YES _____ NO

LOCATION SERVICE:

COUNTRY: _____ CITY: _____

NAME OF MINE: _____

PILOT PLANT REQUIREMENTS: BE VERY SPECIFIC

PROCESS CONDITIONS; (EXAMPLES; High temps or Pressure, slurries)

FLAMMABLE CONDITIONS A POSSIBILITY? _____ YES _____ NO

IF YES EXPLAIN; _____

INSTRUMENTATION PACKAGE REQUIREMENTS:

FLOW RATE (TPH, kg/HR, GPM) _____

MATERIAL OF CONSTRUCTION: _____

UTILITIES AT WORK SITE – ELECTRICAL

VOLTAGE: _____ FREQ: _____ PHASE: _____

GENERATOR: _____ YES _____ NO

WATER –IF APPLICABLE

PIPE SIZE: _____ MATERIAL: _____

GPM: _____

PNEUMATIC – IF APPLICABLE

PRESSURE _____

LOCATION DESCRIPTION AND INFORMATION

SIZE OF BUILDING: _____ SQ FT.

HEIGHT OF CEILING: _____ FT.

GA DRAWINGS AVAILABLE: _____ YES _____ NO

ALTITUDE: _____ ft.

TEMP: _____ F/ C

WIND: _____ AVG MPH

GROUND CONDITIONS AT WORKSITE: _____

PRECIPITATION (IF OUTSIDE): _____

INDOOR/OUTDOOR: _____

PLANT MOBILITY: CASTERS _____ SKIDS _____ N/A _____

HAZARD RECOGNITION ON SITE:

ELECTRIC: _____

TOXIC SUBSTANCE: _____

OTHER: _____

IF YES TO THE ABOVE, PLEASE PROVIDE SEPOR WITH COMPLIANCE INFORMATION:

SITE ACCESS:

BRIEFLY EXPLAIN: _____

DOES THE WORKSITE HAVE LIFTING AND MOVING EQUIPMENT?

_____ YES _____ NO

TYPE: _____

SITE READINESS:

PLEASE EXPLAIN: _____

WILL YOU REQUIRE SEPOR FIELD TECHNICIANS TO INSTALL, COMMISSION AND SUPERVISE?

***INFORMATION ON THIS FORM IS CONFIDENTIAL AND HELD IN STRICT CONFIDENCE.**

RETURN COMPLETED PDF TO INFO@SEPOR.COM